

INSTALLATION AND MAINTENANCE INSTRUCTIONS

2-WAY DIAPHRAGM OPERATED
SOLENOID VALVES - 3/8, 1/2 AND 3/4 N.P.T.
NORMALLY CLOSED CONSTRUCTION

BULLETIN

8215

ASCO®

DESCRIPTION

Bulletin 8215's are 2-way, normally closed, internal pilot, diaphragm operated solenoid valves with die cast aluminum bodies for air and gas service. The standard valves have a General Purpose, NEMA Type 1 Solenoid Enclosure. Valves may be equipped with an enclosure which is designed to meet NEMA Type 4 - Watertight, NEMA Type 7 (C or D) Hazardous Locations - Class I, Group C or D, and NEMA Type 9 (E, F or G) Hazardous Locations - Class II, Group E, F or G. For Installation and Maintenance Instructions for Explosion-Proof/Watertight Solenoids, refer to Form No. V-5391 or V-5380.

OPERATION

Normally Closed: Valve opens when solenoid is energized and closes when solenoid is de-energized.

IMPORTANT: Minimum pressure differential 5 P.S.I.

INSTALLATION

Check nameplate for correct catalog number, pressure, voltage and service.

TEMPERATURE LIMITATIONS

For maximum valve ambient and fluid temperature limitations, refer to the following chart. The temperature limitations listed are for UL applications. For other valves and non-UL applications, higher ambient and fluid temperature limitations are available. Consult factory. Check catalog number on nameplate to determine maximum temperature.

Construction	Coil Class	Catalog Number Prefix	Maximum Ambient Temp. °F	Maximum Fluid Temp. °F
A-C Construction (Alternating Current)	A	None	77	77
	F	FT	104	104
	H	HT	140	140
D-C Construction (Direct Current)	A, F or H	None, FT or HT	77	77

POSITIONING/MOUNTING (Refer to Figure 1)

A-C Construction - valve is designed to perform properly when mounted in any position. However, for optimum life and performance, the solenoid should be mounted vertical and upright so as to reduce the possibility of foreign matter accumulating in the core tube area.

D-C Construction - valve must be mounted with solenoid vertical and upright.

PIPING

Connect piping to valve according to markings on valve body. Apply pipe compound sparingly to male threads only; if applied to valve threads, it may enter valve and cause operational difficulty. Pipe strain on valve body should be avoided by proper support and alignment of piping. When tightening connections, do not use body or solenoid as a lever. Wrenches applied to valve body or piping are to be located as close as possible to connection point.

CAUTION: To avoid damage to the valve body, DO NOT OVERTIGHTEN PIPE CONNECTIONS. If teflon tape, paste, spray or similar lubricant is used, use extra care due to reduced friction.

IMPORTANT: For protection of the solenoid valve, install a strainer or filter suitable for the service involved in the inlet side as close to valve as possible. Periodic cleaning is required depending on service conditions. See Bulletins 8600, 8601 and 8602 for strainers.

WIRING

Wiring must comply with Local and National Electrical Codes. Housings for all solenoids are made with connections for 1/2 inch conduit. The general purpose solenoid enclosure may be rotated to facilitate wiring by removing the retaining cap or clip. **CAUTION:** When metal retaining clip disengages, it will spring upward. Rotate to desired position. Replace retaining cap or clip before operating.

NOTE: Alternating Current (A-C) and Direct Current (D-C) Solenoids are built differently. To convert from one to the other, it is necessary to change the complete solenoid.

SOLENOID TEMPERATURE

Standard catalog valves are supplied with coils designed for continuous duty service. When the solenoid is energized for a long period, the solenoid enclosure becomes hot and can be touched by the hand only for an instant. This is a safe operating temperature. Any excessive heating will be indicated by the smoke and odor of burning coil insulation.

MAINTENANCE

WARNING: Turn off electrical power supply and depressurize valve before making repairs. It is not necessary to remove valve from pipe line for repairs.

CLEANING

A periodic cleaning of all solenoid valves is desirable. The time between cleanings will vary, depending upon media and service conditions. In general, if the voltage to the coil is correct, sluggish valve operation, excessive leakage or noise will indicate that cleaning is required. Be sure to clean valve strainer or filter when cleaning solenoid valve.

PREVENTIVE MAINTENANCE

1. Keep medium flowing through valve as free from dirt and foreign material as possible.
2. While in service, operate valve at least once a month to insure proper opening and closing.
3. Periodic inspection (depending on media and service conditions) of internal valve parts for damage or excessive wear is recommended. Thoroughly clean all parts. Replace any parts that are worn or damaged.

IMPROPER OPERATION

1. **Faulty Control Circuit:** Check electrical system by energizing solenoid. A metallic click signifies that the solenoid is operating. Absence of the click indicates loss of power supply. Check for loose or blown-out fuses, open circuited or grounded coil, broken lead wires or splice connections.
2. **Burned-Out Coil:** Check for open circuited coil. Replace coil if necessary.
3. **Low Voltage:** Check voltage across the coil leads. Voltage must be at least 85% of nameplate rating.
4. **Incorrect Pressure:** Check valve pressure. Pressure to the valve must be within range specified on nameplate.
5. **Excessive Leakage:** Disassemble valve and clean all parts. Replace parts that are worn or damaged with a complete Spare Parts Kit for best results.

COIL REPLACEMENT

Turn off electrical power supply and disconnect coil lead wires.

1. Remove retaining cap or clip, nameplate and cover. **CAUTION: When metal retaining clip disengages, it will spring upward.**
2. Slip yoke containing coil, sleeves and insulating washers off solenoid base sub-assembly. For D-C Construction, slip spring washer, coil and insulating washers off solenoid base sub-assembly.
3. Reassemble in reverse order of disassembly paying careful attention to exploded views provided for identification and placement of parts.

CAUTION: Solenoid must be fully reassembled as the housing and internal parts are part of and complete the magnetic circuit. Place insulating washers at each end of coil, if required.

VALVE DISASSEMBLY

Depressurize valve and turn off electrical power supply. Proceed in the following manner:

1. Remove retaining cap or clip and slip entire solenoid enclosure off solenoid base sub-assembly. **CAUTION: When metal retaining clip disengages, it will spring upward.**
2. **A-C CONSTRUCTION** (Refer to Figure 2)
 - A. Remove bonnet screws (4) and lift solenoid base sub-assembly off valve body.
 - B. Remove core spring, core assembly and diaphragm spring.**D-C CONSTRUCTION** (Refer to Figure 3)
 - A. Unscrew solenoid base sub-assembly and remove bonnet gasket.
 - B. Remove bonnet screws (4) and lift bonnet off valve body.
 - C. Remove core assembly and core spring.
3. Remove diaphragm assembly. **CAUTION: Do not damage pilot seat on upper side of diaphragm.**
4. Remove body gasket.
5. All parts are now accessible for cleaning or replacement. Replace worn or damaged parts with a complete Spare Parts Kit for best results.

VALVE REASSEMBLY

1. Clean all parts and passageways thoroughly.
2. Reassemble in reverse order of disassembly paying careful attention to exploded views provided for identification and placement of parts.
3. When replacing core spring in core for A-C Construction, closed end of spring must protrude from top of core.
4. For D-C Construction, torque solenoid base sub-assembly to 175 ± 25 inch pounds.
5. Torque bonnet screws (4) to 110 ± 10 inch pounds.
6. After maintenance, operate valve a few times to be sure of proper opening and closing.

SPARE PARTS KITS

Spare Parts Kits and Coils are available for ASCO valves. Parts marked with an asterisk (*) are supplied in Spare Parts Kits.

**ORDERING INFORMATION
FOR SPARE PARTS KITS**
When Ordering Spare Parts Kits or Coils
Specify Valve Catalog Number,
Serial Number and Voltage.

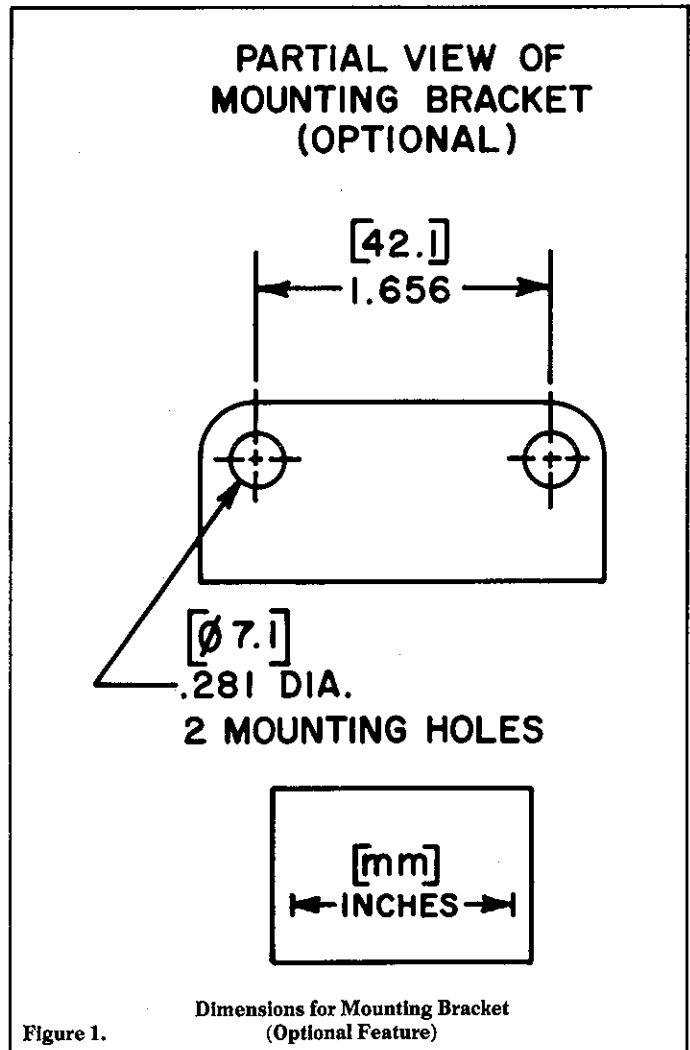

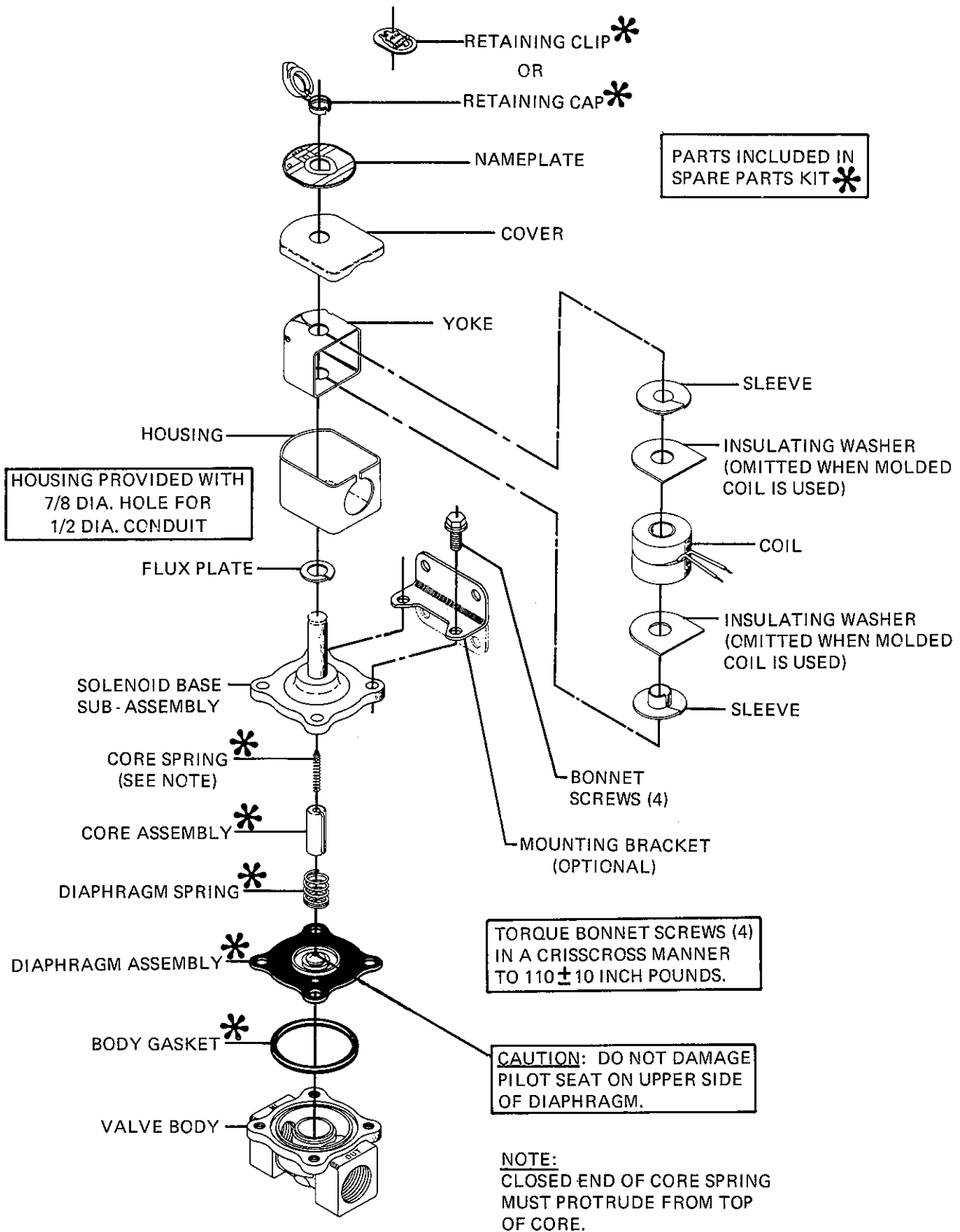

Figure 2.

Bulletin 8215 - A-C Construction
3/8, 1/2 and 3/4 N.P.T.
General Purpose Solenoid Enclosure Shown.
For Explosion-Proof/Watertight Solenoid Enclosure, See Form No. V-5391.

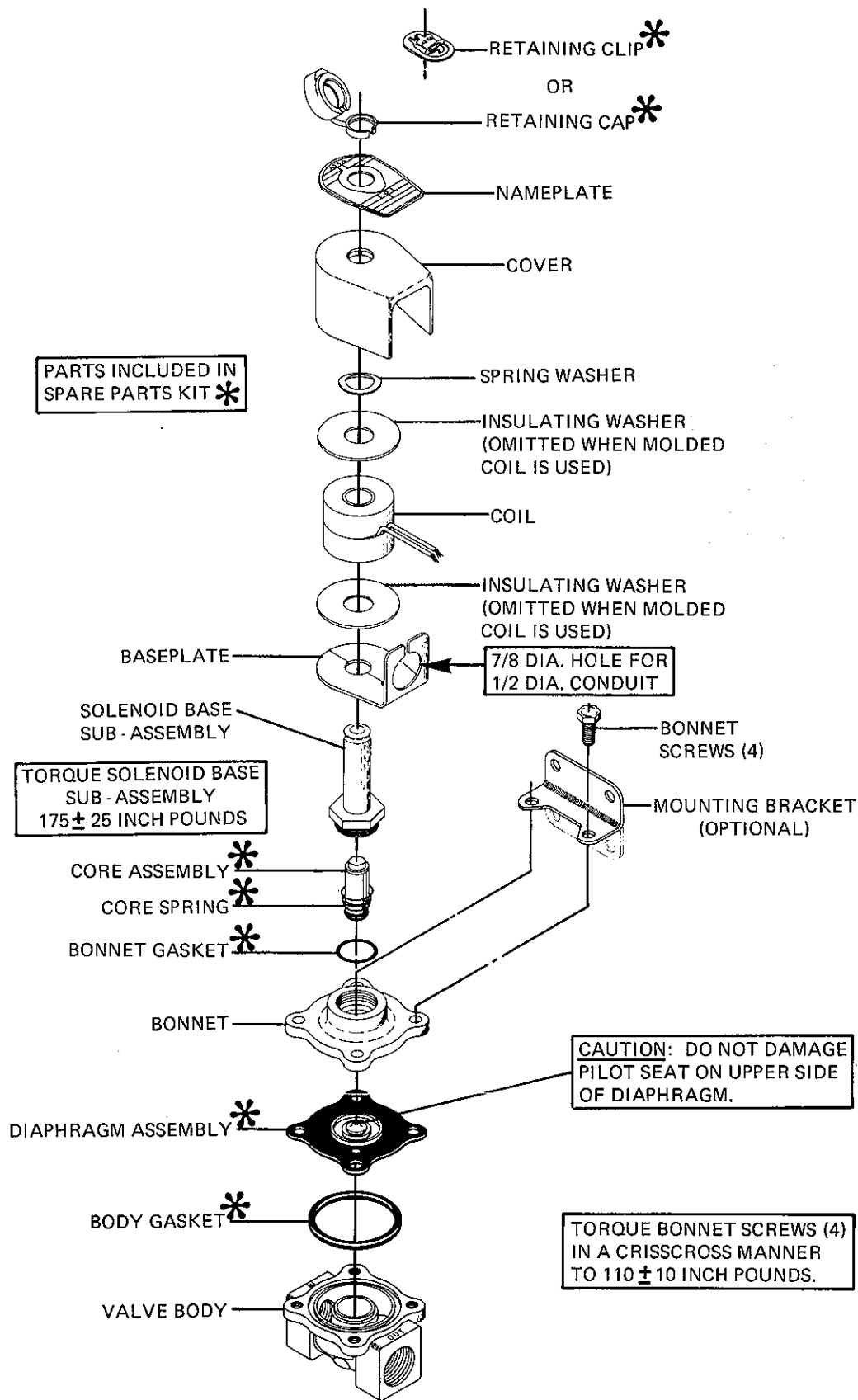

Figure 3.

Bulletin 8215 - D-C Construction
 3/8, 1/2 and 3/4 N.P.T.
 General Purpose Solenoid Enclosure Shown.
 For Explosion-Proof/Watertight Solenoid Enclosure, See Form No. V-5380.